

# ELEVAH<sup>®</sup> 40 MOVE picking



PRODUCT OF THE YEAR 2015



The **self propelled** machine for safe picking activities to up to 4 metres, with **automatic elevation** and a 24 volt battery.

The **AGM 45A batteries** allow to double the autonomy of the machine.

ELEVAH 40 MOVE PICKING



## MANUAL REMOTE CONTROL

The manual remote control adjusts the picking platform in the height, even when loaded, leaving the operator staying in the basket.



SELF PROPELLED

STOCK PICKERS

## SOME ACCESSORIES AND CUSTOMISATION



**C:** belt with winder to block goods during picking activities



**40 PR:** Adjustable banks for picking platform.

➤ OTHER ACCESSORIES AND CUSTOMISATION ON P. 46



# ELEVAH<sup>®</sup> 40 B picking



The picking machine with an elevation of up to 4 metres, having **manual traction** and **automatic elevation** with a 24-volt battery.



EXTENDIBLE  
PICKING PLATFORM

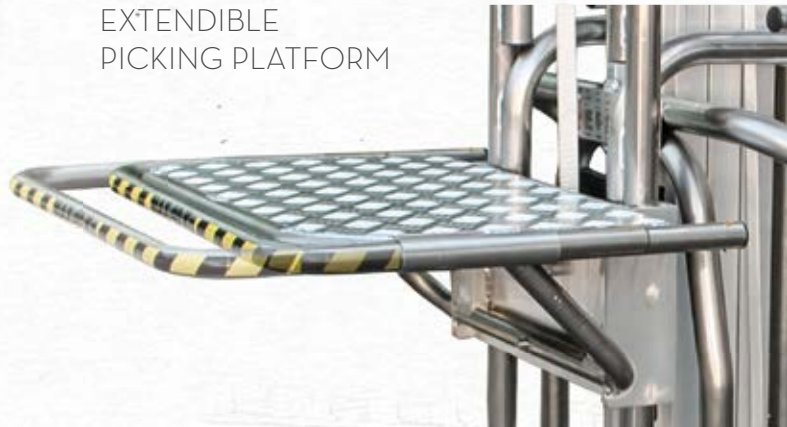

PUSH AROUND MACHINE



PUSH AROUND MACHINE - MAX. WORKING HEIGHT 4 M

CE Complies with European regulations for man-up forklift trucks.  
UNI EN ISO 3691-1.



**Faraone**  
Industrie spa

ELEVAH 40B PICKING

STOCK PICKERS

# ELEVAH<sup>®</sup> 40 MOVE picking

## TECHNICAL DATA

<b>Max. working height</b>		4,00 m
<b>Max capacity</b>		150 kg
<b>Number of people</b>		1
<b>Use</b>		Internal - External
<b>A</b>	<b>Closed machine height</b>	1550 mm
<b>B</b>	<b>Minimum platform height</b>	300 mm
<b>C</b>	<b>Maximum platform height</b>	1930 mm
<b>D/E</b>	<b>Base overall dimensions</b>	1435 x 740 mm
<b>F/G</b>	<b>Cage dimensions</b>	680 x 740 mm
<b>Machine weight</b>		200 kg
<b>Fixed picking tray dimensions</b>		280 x 740 mm
<b>Driving (steering) wheel size</b>		Ø 190 x 60
<b>Swivel wheels dimensions (fixed)</b>		Ø 150 x 45

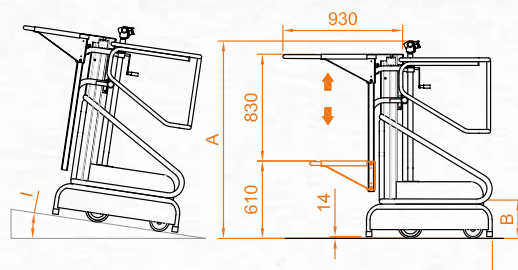

## PICKING PLATFORM

<b>Adjustment</b>		manual
<b>H</b>	<b>Stroke</b>	830 mm
<b>Min. height from the ground</b>		610 mm
<b>Maximum height from the ground</b>		3100 mm
<b>I/J</b>	<b>Dimensions</b>	450 (660) x 725 mm
<b>Capacity</b>		40 kg

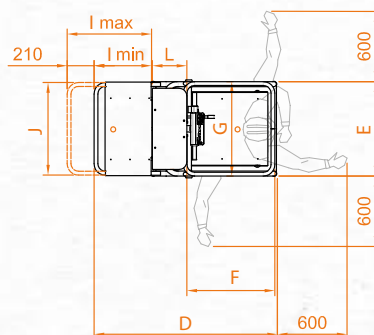

## PERFORMANCE

<b>Power supply</b>		electric
<b>Batteries</b>		2 AGM 12V 45 Ah*
<b>Battery charger</b>		110V - 220V
<b>K</b>	<b>Maximum climbing ability</b>	15%
<b>Internal turning radius</b>		0
<b>External turning radius</b>		1400 mm
<b>Max. speed (rising - descending)</b>		0,08 - 0,10 m/s
<b>Maximum shifting speed</b>		1,3 m/s
<b>Work cycles ** (with fresh batteries)</b>		Ca. 100

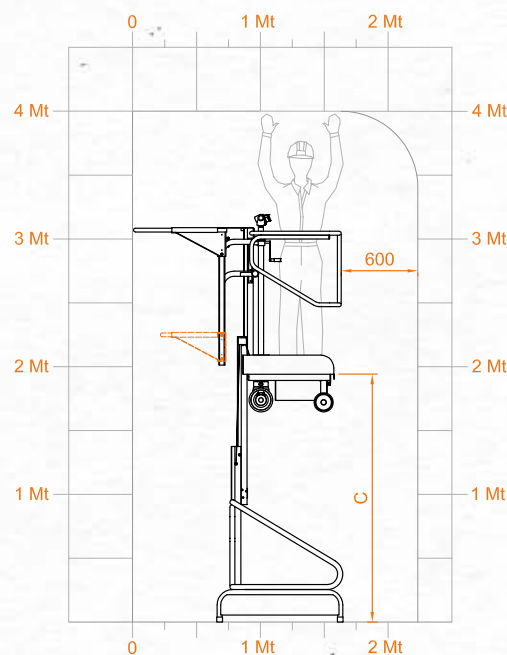

\* Optional - 40BGM

\*\* By work cycle we mean a self-propelled movement of 20 m with a full ascent to and descent from the maximum height.

The machine can work at temperatures between -15° C and +40° C

**CE** Complies with European regulations for man-up forklift trucks. UNI EN ISO 3691-1. In assessing compliance, only those standards whose proposed measures have been implemented were considered and only if a corresponding risk does indeed exist.

www.faraone.com | www.elevah.com